



Republic of the Philippines  
Department of Agriculture  
**BUREAU OF AGRICULTURAL AND FISHERIES ENGINEERING (BAFE)**  
SRA Compound, North Avenue, Quezon City  
Tel No. (02) 8294-6452 Fax No. (02) 941-8151  
Email add: [bafe.da.gov.ph](mailto:bafe.da.gov.ph)

## **REQUEST FOR QUOTATION**

Date: **October 12, 2021**

RFQ No.: **0136-21**

**Name of Supplier / Company:** \_\_\_\_\_

**Address:** \_\_\_\_\_

**TIN:** \_\_\_\_\_

The **Department of Agriculture - Bureau of Agricultural and Fisheries Engineering (BAFE)**, through its **Bids and Awards Committee (BAC)**, intends to procure for **Supply, Delivery, and Installation of Office Furniture and Fixtures for the PPMD** which will be undertaken in accordance with Section 53.9 (Small Value Procurement) of the 2016 Revised Implementing Rules and Regulations of Republic Act No. 9184.

Please quote your best offer for the item/s described herein, subject to the Terms and Conditions provided at the last page of this Request for Quotation (RFQ). Submit your quotation/proposal **duly signed by you or your duly authorized representative** not later than **October 19, 2021 at 12:00 noon**.

**A copy of your 2021 Mayor's/Business Permit and PhilGEPS Registration Number/Certificate Number are also required to be provided along with your signed quotation.**

A valid Certificate of PhilGEPS Registration (Platinum Membership) may be submitted in lieu of the said documents. For individuals, a BIR Certificate of Registration may be submitted in lieu of the 2021 Mayor's/Business Permit. Furthermore, Omnibus Sworn Statement (GPPB-prescribed form) for Approved Budget of Contract (ABC) above P50,000.00 and Income/Business Tax Return for Approved Budget of Contract (ABC) above P500,000.00 are required to be submitted per said ABC threshold.

In observance of the Government Procurement Policy Board (GPPB) Resolution No. 09-2020 (*Approving measures for the efficient conduct of procurement activities during a state of calamity, or implementation of community quarantine or similar restrictions*), an expired Mayor's/ Business Permit with Official Receipt of renewal application and Unnotarized Omnibus Sworn Statement (GPPB-prescribed form) are also accepted subject to submission of 2021 Business/Mayor's permit and Notarized Omnibus Sworn Statement after award of contract but before payment.

Open quotations may be submitted, manually at **DA-BAFE BAC Office** at the **BAFE Office SRA Compound, North Avenue, Diliman, Quezon City**. Moreover, an electronic copy of your Quotation can be submitted but the original copy of the quotations must be submitted personally or via courier prior to award of contract.

For any clarification, you may contact us at [bafe.procurement@gmail.com](mailto:bafe.procurement@gmail.com).

  
**ENGR. EMER-ROSE G. ASUG**  
BAC Secretariat Head 





### INSTRUCTIONS

1. Accomplish this RFQ correctly and completely.
2. Do not alter the contents of this form in any way.
3. Failure to comply with any of the mandatory requirements will disqualify your quotation.
4. Failure to follow these instructions will disqualify your entire quotation.

**Sir/Madam:**

After having carefully read and accepted the Terms and Conditions, I/We submit our quotation for the item/s as follows:

1. Please quote your best offer for the items below. **Please do not leave any blank items. Items with no price indicated shall be considered non-compliant but specifying "0" (zero) or "-" (dash) for the said item would mean that it is being offered for free to the Government.**
2. The information stated below shall be the basis for the evaluation and calculation of your quotation.

ITEM DESCRIPTION/ SPECIFICATION	QUANTITY	UNIT	UNIT COST	APPROVED BUDGET FOR THE CONTRACT	PLEASE FILL IN YOUR OFFERED PRICE PER UNIT	PLEASE FILL IN YOUR TOTAL OFFERED PRICE
Umbrella Rack	1	Piece	5,000.00	5,000.00		
LED Wall Clock	1	Piece	4,000.00	4,000.00		
Analog Wall Clock	3	Pieces	1,000.00	3,000.00		
First Aid Cabinet	1	Piece	5,000.00	5,000.00		
Sliding glass cover and aluminum frame for an existing corkboard	1	Piece	14,850.00	14,850.00		
Hanging Cabinet (60 cm x 90 cm x 30 cm)	1	Piece	8,000.00	8,000.00		
Hanging Shelves (180 cm x 30 cm x 30 cm)	1	Piece	13,000.00	13,000.00		
Hanging cabinet with open shelves (130 cm x 60 cm x 30 cm)	1	Piece	14,800.00	14,800.00		
Hanging Cabinet (140 cm x 60 cm x 30 cm)	1	Piece	14,800.00	14,800.00		
Mirror	2	Pieces	3,000.00	6,000.00		
Single-Door Steel Cabinet	1	Piece	14,850.00	14,850.00		
Portable Steel ladder	1	Piece	4,000.00	4,000.00		
Door Knob	6	Pieces	1,500.00	9,000.00		
Lavatory sink with faucet	2	Set	14,000.00	28,000.00		
Podium	1	Piece	25,000.00	25,000.00		
<b>TOTAL ABC</b>			---	<b>169,300.00</b>	---	





Republic of the Philippines  
 Department of Agriculture  
**BUREAU OF AGRICULTURAL AND FISHERIES ENGINEERING (BAFE)**  
 SRA Compound, North Avenue, Quezon City  
 Tel No. (02) 8294-6452 Fax No. (02) 941-8151  
 Email add: [bafe.da.gov.ph](mailto:bafe.da.gov.ph)

- \*The above quoted prices are inclusive of all costs and applicable taxes.
- \*Please see attached Term of Reference

<b>FINANCIAL OFFER</b>	
<b>Approved Budget for the Contract</b>	<b>Total Offered Quotation</b>
<b>One Hundred Sixty-Nine Thousand            Three Hundred Pesos Only            (PhP 169,300.00)</b>	In words: _____ _____ _____ In figures: _____ _____ _____

**Terms of Payment:**

Payment shall be made through Land Bank's LDDAP-ADA/Bank Transfer facility, within thirty (30) days after Submission of Billing and Under Acceptance of the product. Bank Transfer shall be charged against the creditor's account.

**Payment Details:**

Banking Institution: \_\_\_\_\_  
 Account Number: \_\_\_\_\_  
 Account Name: \_\_\_\_\_  
 Branch: \_\_\_\_\_

\_\_\_\_\_  
 Signature over Printed Name

\_\_\_\_\_  
 Position/Designation

\_\_\_\_\_  
 Office Telephone No. / Fax No. / Mobile No.

\_\_\_\_\_  
 Email address/ es

AJA





<b>TERMS AND CONDITIONS:</b>	
1.	Bidders shall provide correct and complete information required in this form. <sup>[L]</sup> <sub>[SEP]</sub>
2.	Price quotation/s must be valid for a period of <b><u>One Hundred Twenty (120) calendar days</u></b> from the date of submission of quotation. <sup>[L]</sup> <sub>[SEP]</sub>
3.	Price quotation/s, to be denominated in Philippine peso shall include all taxes, duties and/or levies payable, including delivery charges.
4.	Quotations exceeding the Approved Budget for the Contract shall be rejected. <sup>[L]</sup> <sub>[SEP]</sub>
5.	Award of contract shall be made to the lowest quotation (for goods and infrastructure) or, the highest rated offer (for consulting services), which complies with the minimum technical specifications and other terms and conditions stated herein. <sup>[L]</sup> <sub>[SEP]</sub>
6.	Any interlineations, erasures or overwriting shall be valid only if they are signed or initialed by you or any of your duly authorized representative/s. <sup>[L]</sup> <sub>[SEP]</sub>
7.	Delivery and/or Installation Period: <b><u>within Thirty (30) calendar days upon conforme of the Work Order.</u></b>
8.	The DA-BAFE shall have the right to inspect and/or to test the goods to validate its conformity to the technical specifications.
9.	In case of two or more bidders are determined to have submitted the Lowest Calculated Quotation/Lowest Calculated and Responsive Quotation, the DA-BAFE shall adopt and employ “draw lots” as the tie-breaking method to finally determine the single winning provider in accordance with GPPB Circular 06-2005. <sup>[L]</sup> <sub>[SEP]</sub>
10.	Payment shall be made thirty (30) days after delivery and acceptance of the item (s) and upon the submission of the required supporting documents, i.e, delivery receipt and/or billing statement, by the supplier.
11.	Liquidated damages equivalent to one tenth of one percent (0.1%) of the value of the goods not delivered within the prescribed delivery period shall be imposed per day of delay. The DA-BAFE shall rescind the contract once the cumulative amount of liquidated damages reaches ten percent (10%) of the amount of the contract, without prejudice to other courses of action and remedies open to it. <sup>[L]</sup> <sub>[SEP]</sub>





### TERMS OF REFERENCE

**TITLE:**



SUPPLY, DELIVERY, AND INSTALLATION OF VARIOUS FURNITURE AND FIXTURE TO BE INSTALLED IN BAFE-PPMD OFFICE IN SRA COMPOUND, QUEZON CITY

**OBJECTIVE:**

For this term of reference, this aims to supply, deliver, and install various office furniture and fixture in BAFE PPMD office. Specifically, this aims to:

1. Provide office furniture and fixture for PPMD employees; and
2. Create storage for PPMD employees





**TECHNICAL SPECIFICATIONS**

ITEM/PARTICULARS	SPECIFICATIONS	SAMPLE PHOTO
Umbrella Rack	*material: paint coated metal any better material *with at least 16 holes *with hook for foldable umbrella *can fit straight umbrella in each hole *with four legs *with bottom tray *rust free	 SAMPLE PHOTO ONLY
LED Digital Wall Clock	*with date, month, year *with temperature reading *time setting: military time 24 hours and AM and PM setting *black plastic casing with acrylic cover *power source: 220V AC power supply and 5V DC adapter *with back-up rechargeable battery *LED color: green or white *at least 17.5" x 7.5" x 2" *wall-mounted *at least 1 year warranty	 SAMPLE PHOTO ONLY









ITEM/PARTICULARS	SPECIFICATIONS	SAMPLE PHOTO
Analog Wall Clock	<ul style="list-style-type: none"> <li>*At least 9 in diameter</li> <li>*Battery operated (1 AA battery)</li> <li>*Color:               <ul style="list-style-type: none"> <li>- Background: Black</li> <li>- Numbers: Color, in contrast with background</li> </ul> </li> </ul>	 <p style="text-align: center; border: 1px solid black; padding: 2px;">SAMPLE PHOTO ONLY</p>
First-Aid Cabinet	<ul style="list-style-type: none"> <li>*Steel coated with white paint</li> <li>*Single Door</li> <li>*With at least two shelves</li> <li>*With lock and key</li> <li>*With extra key</li> <li>*Wall-mounted</li> </ul>	 <p style="text-align: center; border: 1px solid black; padding: 2px;">SAMPLE PHOTO ONLY</p>
Sliding glass cover and aluminum frame for existing corkboard	<ul style="list-style-type: none"> <li>*Wall-mounted</li> <li>*Aluminum or better material frame, painted</li> <li>*Color of frame: white</li> <li>*Should fit an existing 8 ft x 4 ft corkboard/bulletin board</li> <li>*With lock and key</li> <li>*Thickness of clear glass: at least 6 mm</li> </ul>	 <p style="text-align: center; border: 1px solid black; padding: 2px;">SAMPLE PHOTO OF THE EXISTING CORKBOARD TO BE INSTALLED WITH SLIDING GLASS COVER AND ALUMINUM FRAME</p>  <p style="text-align: center; border: 1px solid black; padding: 2px;">WHEN INSTALLED - SAMPLE PHOTO ONLY</p>



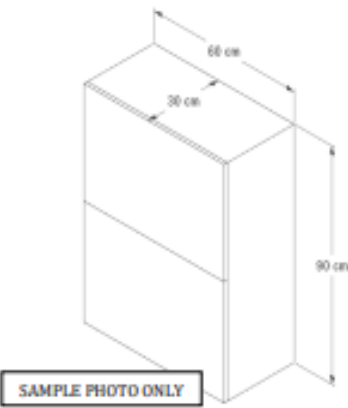
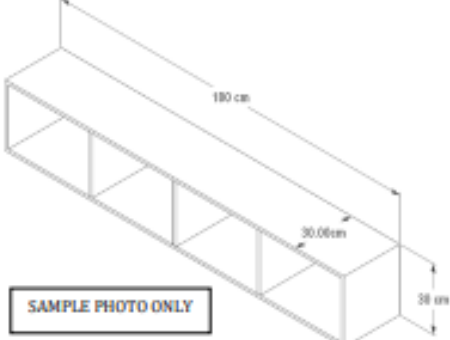

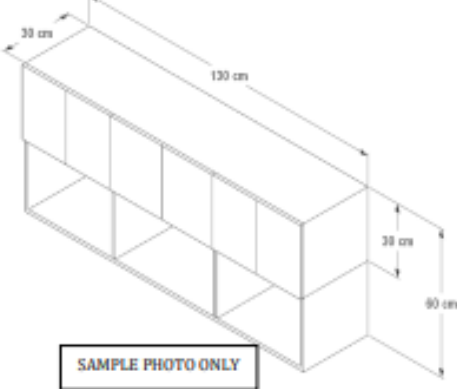
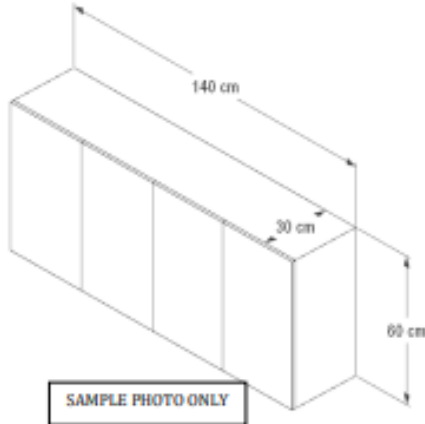



ITEM/PARTICULARS	SPECIFICATIONS	SAMPLE PHOTO
Mirror	<ul style="list-style-type: none"> <li>*At least 5mm glass</li> <li>*One-way mirror</li> <li>*With bevel edges</li> <li>*Portrait orientation</li> <li>*At least 600 mm x 450 mm</li> <li>*With mounting system</li> </ul>	
Hanging cabinet (60 cm x 90 cm x 30 cm)	<ul style="list-style-type: none"> <li>*Wall mounted using at least two (2) metal shelf brackets</li> <li>*Primary material: at least 15 mm thick melamine board</li> <li>*With at least 3 paint coating</li> <li>*Dimension: 60 cm width x 90 cm height x 30 cm depth</li> <li>*With two partitions</li> <li>*Swing-type door</li> <li>*With locking mechanism for door</li> <li>*Color: white, compatible with color of wall</li> </ul>	
Hanging shelves (180 cm x 30 cm x 30 cm)	<ul style="list-style-type: none"> <li>*Wall mounted using at least two (5) metal shelf brackets</li> <li>*Primary material: at least 15 mm thick melamine board</li> <li>*With at least 3 paint coating</li> <li>*Dimension: 180 cm width x 30 cm height x 30 cm depth</li> <li>*With four partitions</li> <li>*Color: white, compatible with color of wall</li> </ul>	

ITEM/PARTICULARS	SPECIFICATIONS	SAMPLE PHOTO
Hanging cabinet with open shelves (130 cm x 60 cm x 30 cm)	<ul style="list-style-type: none"> <li>*Wall mounted using at least two (5) metal shelf brackets</li> <li>*Primary material: at least 15 mm thick melamine board</li> <li>*With at least 3 paint coating</li> <li>*Dimension: 130 cm width x 60 cm height x 30 cm depth</li> <li>*With six partitions</li> <li>*Three partitions above with two-door per partition</li> <li>*Three partitions below, open shelves</li> <li>*Swing-type door</li> <li>*With locking mechanism for door</li> <li>*Color: white, compatible with color of wall</li> </ul>	
Hanging cabinet (140 cm x 60 cm x 30 cm)	<ul style="list-style-type: none"> <li>*Wall mounted using at least two (5) metal shelf brackets</li> <li>*Primary material: at least 15 mm thick melamine board</li> <li>*With at least 3 paint coating</li> <li>*Dimension: 140 cm width x 60 cm height x 30 cm depth</li> <li>*With four partitions</li> <li>*Swint-type door</li> <li>*With locking mechanism for door</li> <li>*Color: white, compatible with color of wall</li> </ul>	
Lavatory sink with faucet	<ul style="list-style-type: none"> <li>*Sink dimension: At least 40 cm width, At least 50 cm length</li> <li>*Ceramic Porcelain Material</li> <li>*With single faucet hole</li> <li>*At least 52mm mounting hole diameter</li> <li>*Full pedestal type</li> <li>*At least 304 stainless steel faucet</li> <li>*At least 3" spout height</li> <li>*With single handle</li> </ul>	



ITEM/PARTICULARS	SPECIFICATIONS	SAMPLE PHOTO
Single-Door Steel Cabinet	<ul style="list-style-type: none"> <li>*Single door</li> <li>*With at least 3 paint coating</li> <li>*With partition for storing spray bottles</li> <li>*With partition for storing detergent or bleach powder in a gallon container</li> <li>*With at least one horizontal pole and three hangers for mop</li> <li>*With at least two hangers for drying towels</li> <li>*With louvers or ventilation holes</li> <li>*With lock and keys</li> <li>*Minimum dimensions: 1850 mm L x 450 mm W x 250 mm D</li> <li>*Design, supply, fabrication, and delivery should be included in the cost</li> </ul>	 <p style="text-align: center;">SAMPLE PHOTO ONLY</p>
Podium	<ul style="list-style-type: none"> <li>*material:</li> <li>*base: wood with glossy natural looking varnish</li> <li>*body: acrylic-white bolted to the wood using stainless stand off bolt (front), sides (same with base, wood with glossy natural looking varnish)</li> <li>*top: clear acrylic or wood with glossy natural looking varnish</li> <li>*with BAFE name and logo on the surface of the front acrylic</li> <li>*at least 60 cm length</li> <li>*at least 60 cm width</li> <li>*at most 120 cm height</li> </ul>	 <p style="text-align: center;">SAMPLE PHOTO ONLY</p>
Foldable steel ladder	<ul style="list-style-type: none"> <li>*At least 3 steps ladder</li> <li>*Foldable</li> <li>*Anti rust</li> <li>*Height: at least 110cm from base to tip</li> <li>*Length: at least 65cm (side when open), at least 45cm (front when open)</li> <li>*Rubber or any better material for step with anti-slip feature</li> </ul>	 <p style="text-align: center;">SAMPLE PHOTO ONLY</p>



ITEM/PARTICULARS	SPECIFICATIONS	SAMPLE PHOTO
Door Knob	*Lever type *Stainless steel *With at least 2 spare keys *Anti rust and durable *Can be used for left or right sided door *Lock function with push button	 <p style="text-align: center;">SAMPLE PHOTO ONLY</p>

**SCHEDULE OF DELIVERY:**

The schedule of delivery should be Thirty (30) days upon conforme of the Work Order.

**PAYMENT**

Payment shall be done within thirty (30) calendar days upon receipt, inspection, and acceptance of the various furniture and fixture including documents such as Official Receipt/Billing Statement/Statement of Account and other necessary documents.

**OTHER REQUIREMENTS:**

For the purpose, the following are additional requirements for the various furniture and fixture listed above:

- Delivery, mounting and Installation cost is included in the cost
- At least 1-Year Manufacturer Warranty from the date of acceptance

Prepared by:

  
**MS. RHONALYN F. VILLAMIN**  
 Administrative Officer III, BAFE-PPMD

  
**ENGR. GLENN M. OCA**  
 Engineer II, BAFE-PPMD

Approved by:

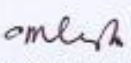
  
**ENGR. CRISTY CECILIA P. POLIDO**  
 Chief, BAFE-PPMD





Republic of the Philippines  
Department of Agriculture  
**BUREAU OF AGRICULTURAL AND FISHERIES ENGINEERING (BAFE)**  
SRA Compound, North Avenue, Quezon City  
Tel No. (02) 8294-6452 Fax No. (02) 941-8151  
Email add: [bafe.da.gov.ph](mailto:bafe.da.gov.ph)





Republic of the Philippines  
Department of Agriculture  
**BUREAU OF AGRICULTURAL AND FISHERIES ENGINEERING (BAFE)**  
SRA Compound, North Avenue, Quezon City  
Tel No. (02) 8294-6452 Fax No. (02) 941-8151  
Email add: [bafe.da.gov.ph](mailto:bafe.da.gov.ph)

